

ONE COFFEE TABLE ASSEMBLY INSTRUCTIONS

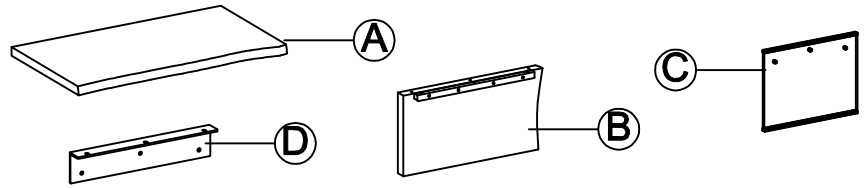

PARTS PACKING CONFIGURATIONS

- A.TOP 1PC
- B.WOOD SIDE PANEL 1PC
- C.GLASS SIDE PANEL 1PC
- D.L-BRACKET 2PCS



HARDWARE KIT PACKED IN BOX

NO.	DESCRIPTION	IMAGE	Q'TY
1	ALLEN BOLT (5/16"x1-1/2")		3 PCS
2	ALLEN BOLT (5/16"x1")		6 PCS
3	LOCK WASHER (5/16")		9 PCS
4	FLAT WASHER (5/16")		9 PCS
5	ALLEN KEY (5mm)		2 PCS
6	CONNECTOR CAP		3 PCS
7	CONNECTOR BOLT (M8x15mm)		3 PCS
8	PLASTIC WASHER (25x2mm)		6 PCS
9	WOOD DOWEL(8x30mm)		3 PCS

FULLY ASSEMBLED

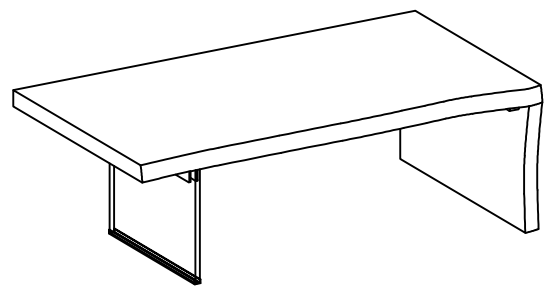

Step 1:

#5 (2)	#6 (3)	#7 (3)	#8 (6)
--------	--------	--------	--------



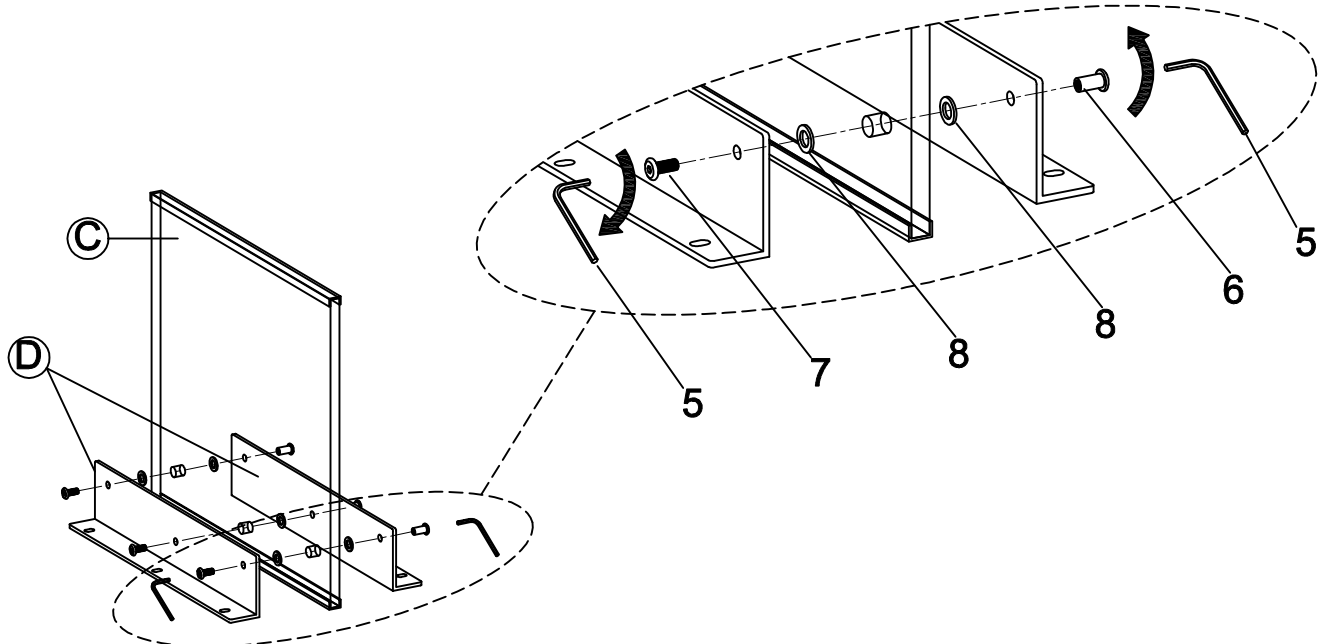



NOTE: DO NOT FULLY TIGHTEN THE BOLTS UNTIL FINAL STEP.



ONE COFFEE TABLE ASSEMBLY INSTRUCTIONS



Step 2:

 #1 (3)	 #2 (6)	 #3 (9)
 #4 (9)	 #5 (1)	 #9 (3)

NOTE: FULLY TIGHTEN ALL BOLTS FROM THIS AND THE PREVIOUS STEP.

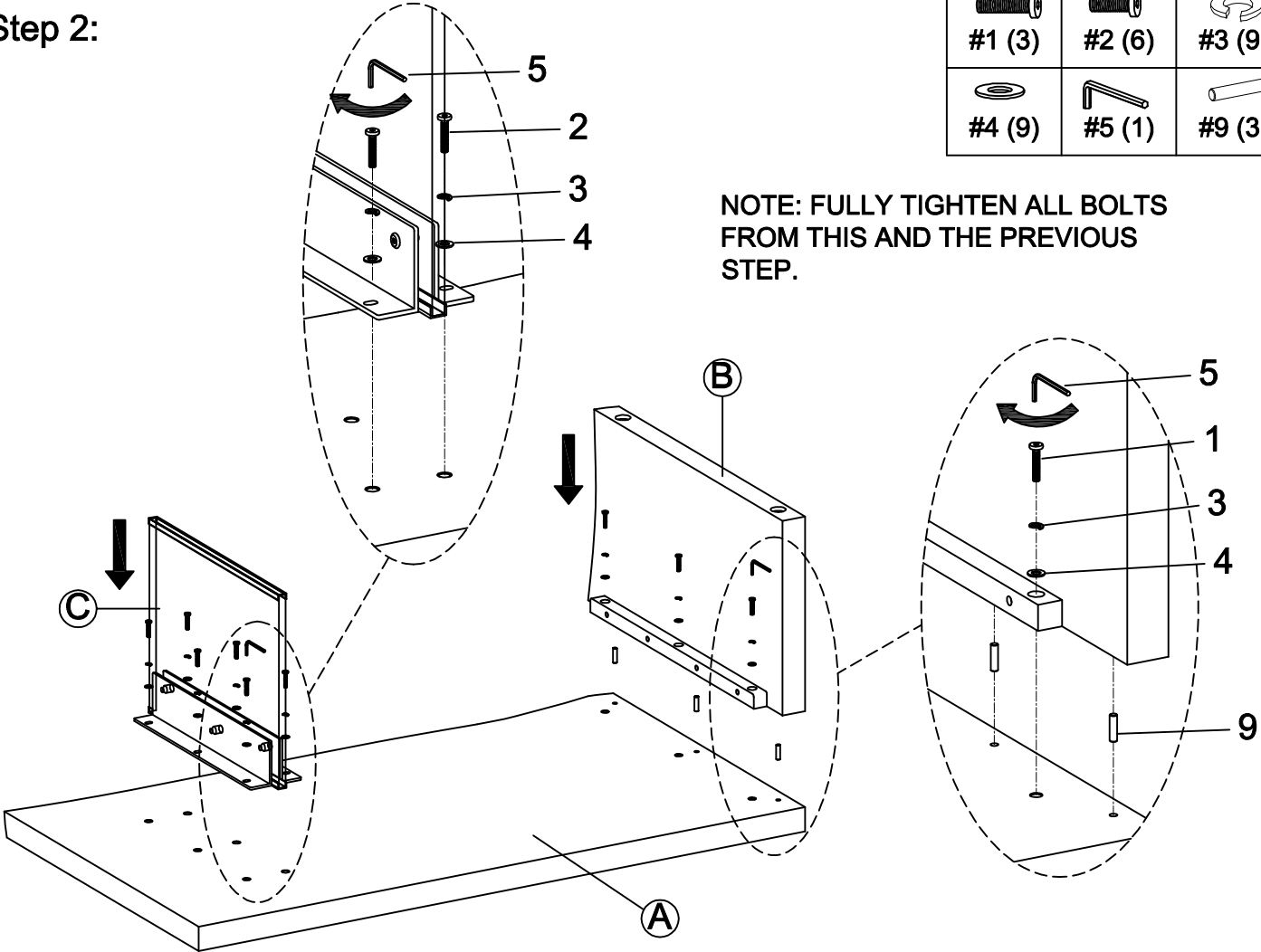

ASSEMBLY COMPLETE

